

- |     |          |                       |
|-----|----------|-----------------------|
| 1   | 20149    | FLANGED BEARING       |
| 2   | 20150    | SLEEVE BEARING        |
| 3   | 23669    | O/S FLUID DRIVE       |
| 4   | 0041846  | NUT                   |
| 5   | 03815    | LOCKWASHER            |
| 6   | 23588    | SHIFTER ARM           |
| 7   | 03814    | SCREW                 |
| 8   | 23589    | SHIFTER ARM           |
| 9   | 20298    | SPRING WASHER         |
| 10  | 20093    | WASHER                |
| 11  | 20087    | CAM BOLT              |
| 12  | 20140    | SPRING RETAINER       |
| 13  | 20091    | DISENGAGING SPRING    |
| 14  | 20274    | NUT                   |
| 15  | 20277    | LOCKWASHER            |
| 16  | 20546    | STOP BRACKET          |
| 17  | 24233    | CAP SCREW             |
| 18  | 20255    | CAP SCREW             |
| 19  | 20274    | NUT                   |
| 20  | 20277    | LOCKWASHER            |
| 21  | 20279    | WASHER                |
| 22  | 20255    | CAP SCREW             |
| 23  | 20104    | LOCKNUT               |
| 24  | 03189    | LOCKWASHER            |
| 25  | 20759    | MOTOR BRACKET         |
| 26  | 20058    | SOLENOID              |
| 27  | M0282405 | NUT                   |
| 28  | 20174    | RIVET                 |
| 28A | 20248    | COTTER PIN            |
| 29  | 20185    | O/S BELT              |
| 30  | 04417P   | MOTOR PULLEY ASSEMBLY |
| 31  | 20084    | RETAINER RING         |
| 32  | 20063    | CLUTCH LINING         |
| 33  | 24417P   | PULLEY                |
| 34  | 24298    | ROLL PIN              |
| 35  | 20102    | RUBBER MOUNT          |
| 36  | M0270519 | WASHER                |
| 37  | 03189    | LOCKWASHER            |
| 38  | 20281    | LOCKNUT               |
| 39  | 20545    | ENGAGING SPRING       |
| 40  | 20561    | SOLENOID LINK         |

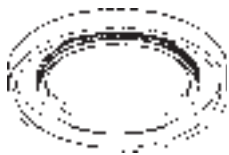

20199  
Speed Queen Washer Oil Seal,  
Transmission/Clutch Seal.



20200  
Speed Queen Washer  
Transmission Pinion Seal.

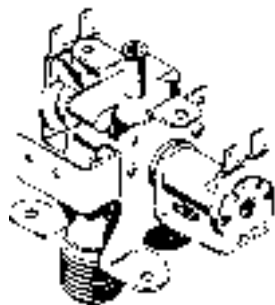

21713  
24596  
24597  
Speed Queen Washer  
Water Valve.

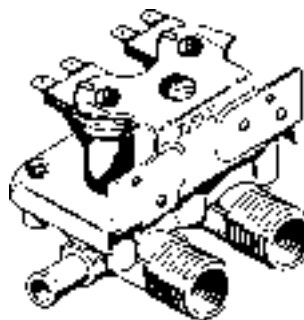

33930  
25832  
25833  
Speed Queen Washer Water  
Valve.









27612  
Speed Queen Lid Switch.

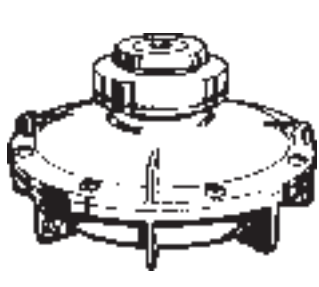
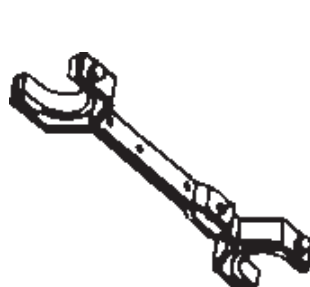
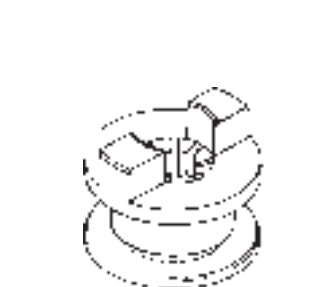
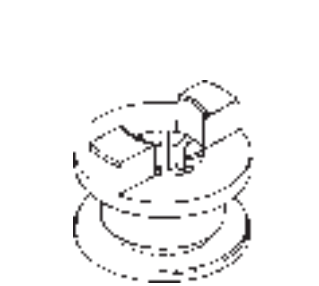
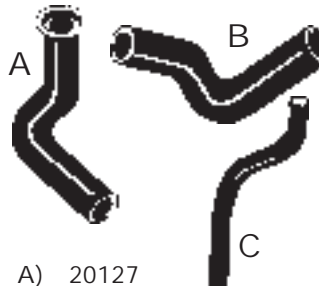

51143      Early Models  
504570      Current Models  
Speed Queen Washer Lid Switch.

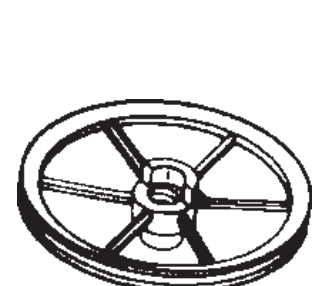
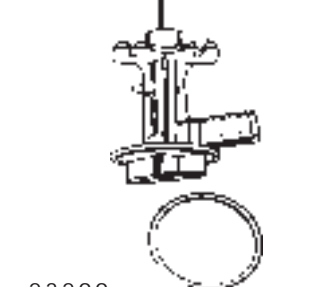
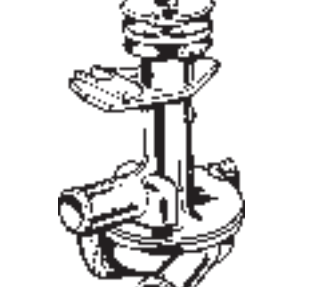
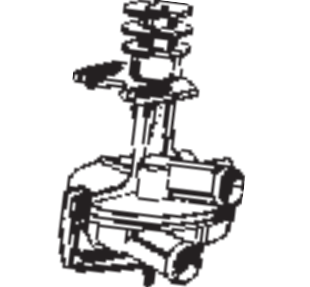
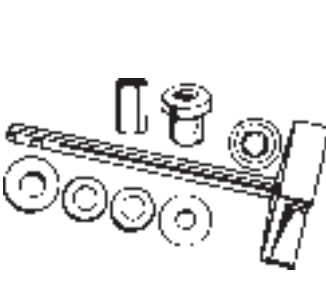
# WASHER COMPONENTS

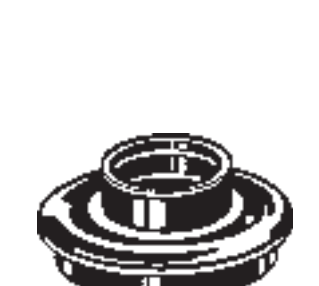
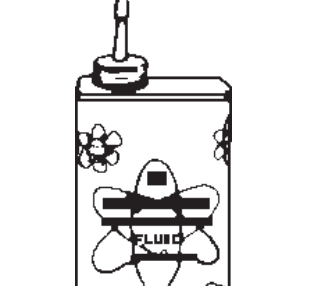
# SPEED QUEEN

 <p>24706 Speed Queen Washer New Style Fluid Drive Assembly.</p>	 <p>23669 Speed Queen Old Style Washer Fluid Drive.</p>	 <p>23732 Speed Queen New Style Washer Agitator Shift &amp; Collars.</p>	 <p>23647 Speed Queen New Style Shift Clutch 1 9/16" Wide.</p>
 <p>20078 Speed Queen Old Style Washer Clutch 1 5/16" Wide.</p>	 <p>A) 20127 B) 22782 C) 21254 Speed Queen Washer Pump Outlet Hoses.</p>	 <p>25112 Speed Queen Washer Drain Tube Outlet Hose.</p>	 <p>23773 Speed Queen Washer Transmission Pulley.</p>
 <p>23299 Speed Queen Washer Pump Body Kit 9 Includes Seals/ Bearings/Gasket Impeller Shaft &amp; Body.</p>	 <p>25178 Speed Queen New Style Pump, 3/8" Drive Belt Pulley.</p>	 <p>23302 - NLA Speed Queen Old Style Pump Assembly 1/2" Drive Belt Pulley.</p>	 <p>131P3 Speed Queen New Style Washer Pump Repair Kit for 25178.</p>
 <p>25277 Speed Queen Washer Clothes Guard.</p>	 <p>20129 Speed Queen Washer Boot.</p>	 <p>20299P (20299) Speed Queen Washer Fluid Drive Oil.</p>	 <p>21751P Speed Queen Washer Agitator Shaft Assembly with Drive Block.</p>

SPEEDQUEEN

Part numbers and illustrations intended solely for identification. Items offered for sale not represented to be manufactured by the company that built the item.

WEST TUCSON  
520.293.8888

LAS VEGAS  
702.382.6532

RENO  
775.348.9090

SALT LAKE CITY  
801.975.1333

SAN ANTONIO  
210.223.2675

SAN ANTONIO  
210.525.0636

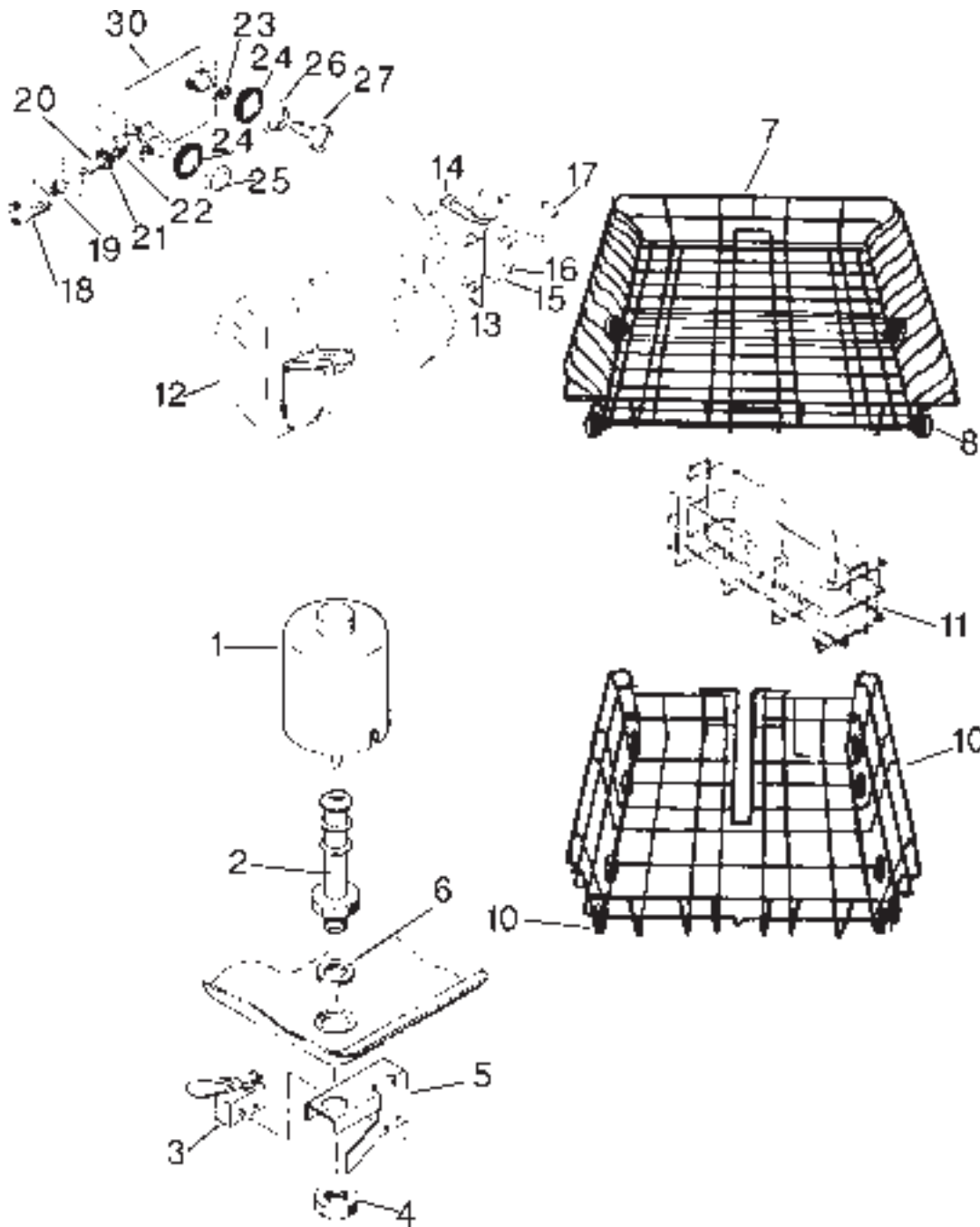

1	01-33-967	Float	13	01-35-140	Latch Assy.
2	01-33-971	Float Guide	14	01-34-292	Bi-Metal
3	01-34-543	Float Switch	15	01-33-861	Detergent Cup Arm
4	00-44-428	Heater Float Switch Nut	16	00-57-347	Screw
5	01-33-966	Float Switch Bracket	17	01-30-238	Spring
6	01-34-143	Float guide Washer	18	00-000-000	Solenoid, Rinse
7A	01-34-628	Upper Basket			Dispensor
7B	01-33-234	Upper Basket Insert	19	00-64-467	Spring
7C	01-33-235	Upper Basket Insert	20	01-32-003	Armature
8	01-34-305	Upper Basket Roller	21	01-32-113	Rinse Diaphragm
9	01-34-735	Lower Basket	22	00-64-466	Seal Ring
10	01-34-304	Lower Basket Roller	23	00-000-000	Gasket
11A	01-34-730	Silverware Basket	24	01-35-055	Grommet
11B	00-09-484	Silverware Basket Cover	25	00-19-555	NLA
12	01-35-074	Detergent cup	26	00-44-384	Rinse Injector Nut
			27	01-32-015	Dip Stick Plug



**Appliance Parts and Maintenance Supplies**

TEMPE:	Ph: 480.755.0005	Fax: 480.755.0008
PEORIA:	Ph: 623.972.5022	Fax: 623.972.4963
NORTH PHOENIX:	Ph: 602.863.3476	Fax: 602.863.2304
SCOTTSDALE:	Ph: 480.970.1010	Fax: 480.970.1215
MESA:	Ph: 480.827.0161	Fax: 480.827.1159
EAST TUCSON:	Ph: 520.751.8800	Fax: 520.751.2495
SOUTH TUCSON:	Ph: 520.624.2102	Fax: 520.791.9132
N. W. TUCSON:	Ph: 520.293.8888	Fax: 520.292.2949
LAS VEGAS:	Ph: 702.382.6532	Fax: 702.382.3487
RENO:	Ph: 775.348.9090	Fax: 775.348.4605
SALT LAKE CITY:	Ph: 801.975.1333	Fax: 801.975.1691

**Typical Replacement Installations**

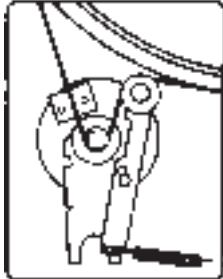

Frigitaire • Kelvinator • Gibson

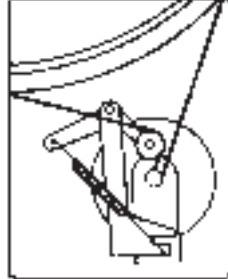

Frigidaire

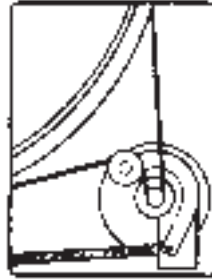

GE

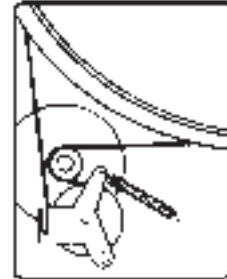

Maytag



Norge

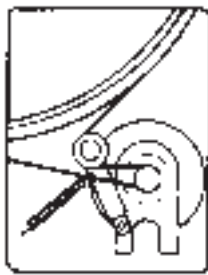

Speed Queen

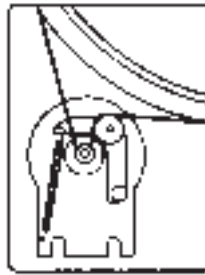

Westinghouse

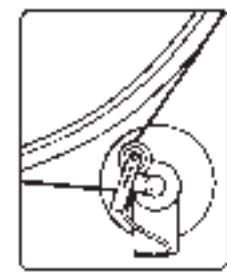

Whirlpool



**Appliance Parts and Maintenance Supplies**

TEMPE:	Ph: 480.755.0005	Fax: 480.755.0008
PEORIA:	Ph: 623.972.5022	Fax: 623.972.4963
NORTH PHOENIX:	Ph: 602.863.3476	Fax: 602.863.2304
SCOTTSDALE:	Ph: 480.970.1010	Fax: 480.970.1215
MESA:	Ph: 480.827.0161	Fax: 480.827.1159
EAST TUCSON:	Ph: 520.751.8800	Fax: 520.751.2495
SOUTH TUCSON:	Ph: 520.624.2102	Fax: 520.791.9132
N. W. TUCSON:	Ph: 520.293.8888	Fax: 520.292.2949
LAS VEGAS:	Ph: 702.382.6532	Fax: 702.382.3487
RENO:	Ph: 775.348.9090	Fax: 775.348.4605
SALT LAKE CITY:	Ph: 801.975.1333	Fax: 801.975.1691

**Typical Wiring Diagram for Shaded-Pole Motors**

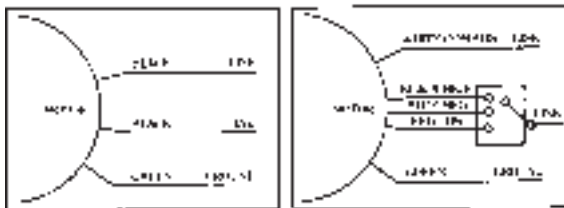

Standard wiring: motor makes as used by FASCO and most other manufacturers for Shaded-Pole motors.

**Typical Wiring Diagram for PSC Motors**

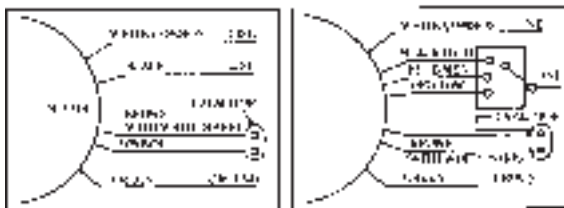

Permanent Split Capacitor motors have many different kinds of wiring arrangements. The standard for FASCO and most other manufacturers is shown.

When the original motor does not have two separate capacitor leads and the original wiring pattern is desired, the following wiring diagram can be used on FASCO 700 series motors.

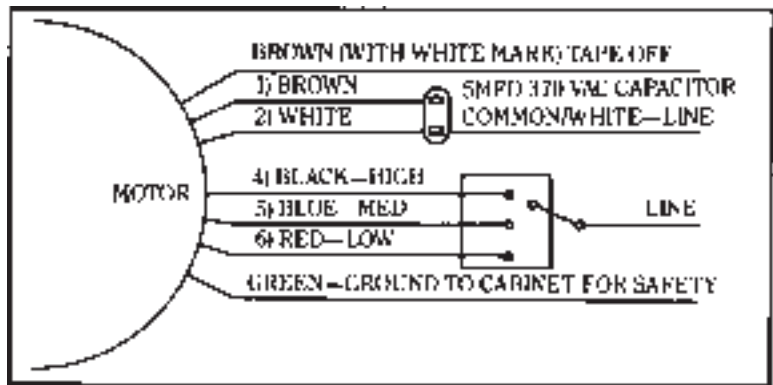



# RETURN GOODS AUTHORIZATION

RGA# \_\_\_\_\_

From (Please Print)

Account Name: \_\_\_\_\_

Contact Name: \_\_\_\_\_

Account #: \_\_\_\_\_

To (Please check appropriate box)

TEMPE: Ph: 480.755.0005 Fax: 480.755.0008

PEORIA: Ph: 623.972.5022 Fax: 623.972.4963

NORTH PHOENIX: Ph: 602.863.3476 Fax: 602.863.2304

SCOTTSDALE Ph: 480.970.1010 Fax: 480.970.1215

MESA Ph: 480.827.0161 Fax: 480.827.1159

EAST TUCSON Ph: 520.751.8800 Fax: 520.751.2495

SOUTH TUCSON Ph: 520.624.2102 Fax: 520.791.9132

N. W. TUCSON Ph: 520.293.8888 Fax: 520.292.2949

LAS VEGAS Ph: 702.382.6532 Fax: 702.382.3487

RENO Ph: 775.348.9090 Fax: 775.348.4605

SALT LAKE CITY Ph: 801.975.1333 Fax: 801.975.1691

DATE		AUTHORIZED BY (APPLIANCE PARTS COMPANY REPRESENTATIVE)						
ITEM #	QTY.	PART#	INVOICE #	REASON FOR RETURN	CREDIT	REPLACE	CREDIT INVOICE NUMBER	RESTK-%
1								
2								
3								
4								
5								
6								

RETURN GOODS VIA	PRE-PAID	COLLECT
<input type="checkbox"/> UPS	<input type="checkbox"/>	<input type="checkbox"/>
<input type="checkbox"/> MAIL	<input type="checkbox"/>	<input type="checkbox"/>
<input type="checkbox"/> OTHER:	<input type="checkbox"/>	<input type="checkbox"/>

COMMENTS:

\_\_\_\_\_

\_\_\_\_\_

\_\_\_\_\_

\_\_\_\_\_

Parts Returned by: \_\_\_\_\_

STAMP HERE

(PLEASE PRINT)

Please Note: RGA # MUST appear on outside of goods being returned, and/or a copy of faxed RGA form  
All Parts Returned Must Be Authorized by an "Appliance Parts Company" Representative



# Research The Fax

DATE: \_\_\_\_\_

TO: Appliance Parts Company

FROM:

ATTENTION: \_\_\_\_\_

LOCATION: \_\_\_\_\_

FAX: \_\_\_\_\_

ATTENTION: \_\_\_\_\_

PHONE: \_\_\_\_\_

FAX: \_\_\_\_\_

PHONE: \_\_\_\_\_

## DESCRIPTION LOOK UP

Product Brand	Model Number	Describe Part
Response (Part # and where found)		

Product Brand	Model Number	Describe Part
Response (Part # and where found)		

Product Brand	Model Number	Describe Part
Response (Part # and where found)		

Product Brand	Model Number	Describe Part
Response (Part # and where found)		

Product Brand	Model Number	Describe Part
Response (Part # and where found)		

Responded By: \_\_\_\_\_

Part numbers and illustrations intended solely for identification. Items offered for sale not represented to be manufactured by the company that built the item.



## CREDIT APPLICATION

APPLICATION FOR:  
CASH ACCOUNT  
Paid by Cash, Check, or Major Credit  
Card at time of purchase  
CREDIT ACCOUNT  
Payment made within credit terms

### BRANCHES

TEMPE	MESA	LAS VEGAS
PEORIA	EAST TUCSON	RENO
NORTH PHOENIX	SOUTH TUCSON	SALT LAKE CITY
SCOTTSDALE	N. W. TUCSON	

### OFFICE ONLY:

Branch Manager Please Check One Box  
L J A B OTHER

### YOUR COMPANY INFORMATION

Registered Company Name (in full) \_\_\_\_\_  
 Street: \_\_\_\_\_ City: \_\_\_\_\_ State: \_\_\_\_\_  
 Zip Code: \_\_\_\_\_ Phone: \_\_\_\_\_ Fax: \_\_\_\_\_  
 Street: \_\_\_\_\_ City: \_\_\_\_\_ State: \_\_\_\_\_  
 Mailing Address:(if different from above)  
 Zip Code: \_\_\_\_\_ Phone: \_\_\_\_\_ Fax: \_\_\_\_\_  
 Email Address: \_\_\_\_\_ Website: \_\_\_\_\_

### BUSINESS INFORMATION

Nature of Business: Appliance Servicer [AS] Appliance Dealer [AD] Residential Property Management [RM] Commercial Property Management [CM] Hotel/Motel [HM]  
 Health Care [HC] Education [EF] Food Service [FS] Correctional [CF] Contractor/Trade[CT] Senior Lodging [SL] Laundry Mat [LM] Other [OB] \_\_\_\_\_  
 How long in business (#years) \_\_\_\_\_ (Please check) Is your business a: Corporation Partnership Sole Proprietorship  
 Please provide names of \_\_\_\_\_ Position \_\_\_\_\_ Address \_\_\_\_\_ Phone \_\_\_\_\_  
 Principles, Owners \_\_\_\_\_ Position \_\_\_\_\_ Address \_\_\_\_\_ Phone \_\_\_\_\_  
 or Partners \_\_\_\_\_ Position \_\_\_\_\_ Address \_\_\_\_\_ Phone \_\_\_\_\_  
 Drivers Lic: \_\_\_\_\_ Social#/or Federal ID \_\_\_\_\_  
 Purchaser/Buyer \_\_\_\_\_ Phone: \_\_\_\_\_ Are Purchase Orders Required? YES NO  
 Accounts Payable \_\_\_\_\_ Phone: \_\_\_\_\_ Do you require monthly statements? YES NO  
 Sales Tax # \_\_\_\_\_ Monthly Credit Limit Request: \_\_\_\_\_  
 Bank: \_\_\_\_\_ Address: \_\_\_\_\_  
 Phone: \_\_\_\_\_ Bank Manager's Name: \_\_\_\_\_

### (3) TRADE REFERENCES

1. NAME: \_\_\_\_\_ ADDRESS: \_\_\_\_\_ PHONE: \_\_\_\_\_  
 2. NAME: \_\_\_\_\_ ADDRESS: \_\_\_\_\_ PHONE: \_\_\_\_\_  
 3. NAME: \_\_\_\_\_ ADDRESS: \_\_\_\_\_ PHONE: \_\_\_\_\_

### TERMS & CONDITIONS

In consideration of credit being granted to the applicant by APPLIANCE PARTS COMPANY for the purpose of goods and services from APPLIANCE PARTS COMPANY the undersigned applicant agrees to the following terms & conditions:  
 A. We agree that any special ordered parts will automatically be charged to this account and we agree to pay for these parts.  
 X \_\_\_\_\_ initials  
 B. That all purchases and other charges incurred by the applicant will be paid on or before the 10th of the following month from date of such purchase or the incurring of such charges.  
 C. To pay late payment fees on the unpaid portion of all the outstanding balances at the rate of 1.5% per month and late payment fees shall be calculated on the unpaid portion of the unpaid balance of the account.  
 D. Payment shall be applied to the late payment fees and secondary to the outstanding balance from time to time.  
 E. The applicant shall promptly notify APPLIANCE PARTS COMPANY of any and all changes in address, name of business, ownership or of any other changes which may be material in determining whether APPLIANCE PARTS COMPANY will continue to grant credit to the applicant.  
 F. That APPLIANCE PARTS COMPANY may make such inquiries of the applicant as are required and as it deems fit at any time relating to the information contained herein and including but not limiting to the foregoing of any renewals or extensions hereof and any information concerning the business of the applicant.  
 G. Applicant and Guarantor(s) understand and agree that if any invoice is not paid in full within the time stated herein, Seller may, in its discretion, refuse to release any further materials until the account is brought current, regardless of whether additional material had been previously ordered. Credit is conditioned on Applicant and Guarantor(s) continuing to meet Appliance Parts Company Credit Policy

### OFFICE ONLY:

ACCOUNT NUMBER: \_\_\_\_\_  
 APPROVED THIS \_\_\_\_\_ DAY OF \_\_\_\_\_  
 CREDIT MANAGER \_\_\_\_\_  
 (Appliance Parts Company)

I authorize Appliance Parts Company to obtain and/or exchange personal information with any personal information agent towards establishing or verifying my financial standing.

NAME (PRINT)

DATE

COMPANY'S REGISTERED OWNER/PARTNER SIGNATURE

